

Orbital Welding (Microfit closed heads)



The Microfitting Series has been designed to weld small diameters tubing and fittings mainly in the semiconductor industry.

This head is a cassette system which allows first to position the parts to be welded in the cassette that is a clamping feature. Once centered and positioned correctly, the welding head is slid in the cassette to correctly position the electrode to the surface to be welded.

The cassette combinations are multiple depending on the type of parts to be welded, tube-tube, tube-union elbow, union elbow-union elbow for example.



The automatic welding cycle can then be started directly through the start button on the motor handle of the head.

The SAXX-200 air cooled is the perfect combination with the SXMF heads to control all steps of the welding cycle. You can refer on all SAXX power sources advantages in the section SAXX power sources.

The SAXX offers functions such as dual digital gas control, auto-calculation of the parameters, compatible competitor head control, USB memory stick, welding data acquisition.

FLEXIBILITY, PRODUCTIVITY

Productivity remains our primary concern. AXXAIR's cassettes have been designed to fit various configurations of different parts to be welded and the weld heads provides high duty cycles.

QUALITY AND REPEATABILITY

The SMMF range allows optimum tube positioning while controlling the tightening forces so as not to distort or mark your tubes.

PORTABILITY

In order to allow you to weld in restrictive conditions and locations, the size and weight of the machines have been significantly reduced.

Our welding cable, housed in an ultra flexible and very resistant protective sheath, also facilitates manipulation of the welding head.

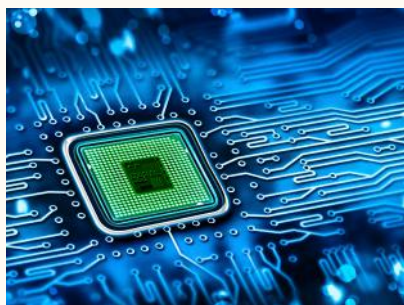

Do not hesitate to contact us for your demands as the applications can be various and the welding configurations multiple.

We will be glad to share our know-how with you and to devise a solution that best meets your needs!



NEW

SXMF-17



AIR cooled
The aluminium hosing on each side of the head protect but also help to evacuate more heat

Compact and light
Weight: 4.5 kg with cable

Thermal shield
We shield the electrode surrounding on the rotor as it is very exposed

Compatible with SAXX welding generators

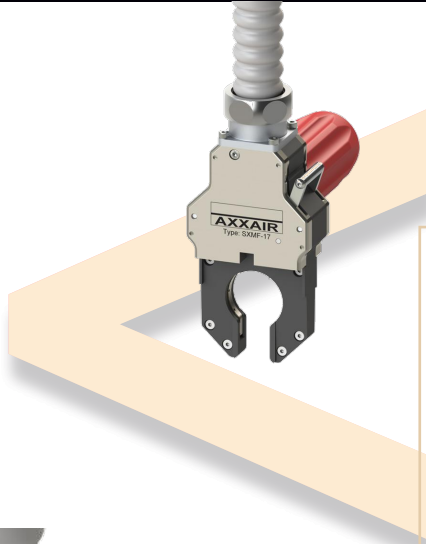
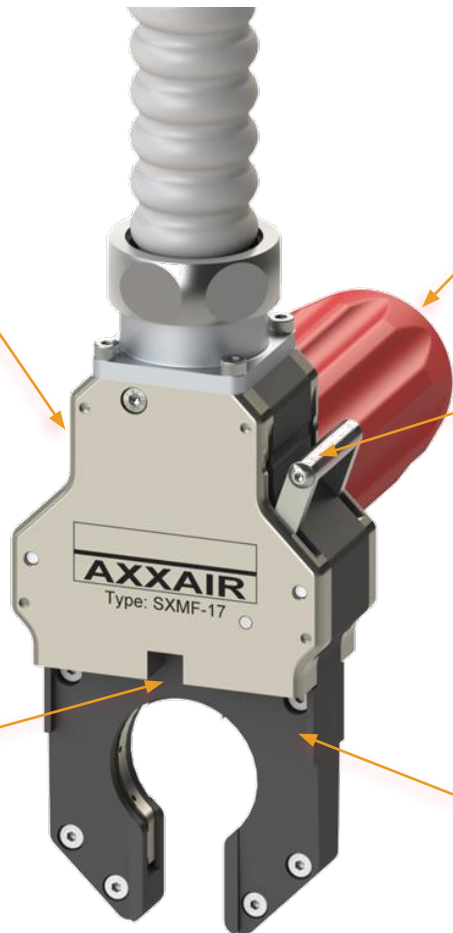

Transport
These heads are delivered in their work site case

Cycle start button
Starting the welding cycle or TEST mode



Cassette locking lever
Allows a stable hold of the cassette when it is placed on the head. Compatible Swagelock cassettes, please contact us

Body with inclined contact surfaces
Allows easy removal of the cassette even when it is hot

Welding range	
SXMF-17	ø3 mm - ø17.2 mm 1/8" - 5/8"



SXMF-17

Technical characteristics:

Maximum welding current for a duty cycle of 35%	70 A
Maximum welding current for a duty cycle of 50%	55 A
Maximum welding current	80 A

- Cable length: 16 feet / 5 meters
- Operating temperature: 32°F to 104°F (0°C to 40°C)

The SXMF-17 is a cassette type orbital welding head. It is controlled by AXXAIR's power sources. The air cooled SAXX-200 orbital power supply is recommended.

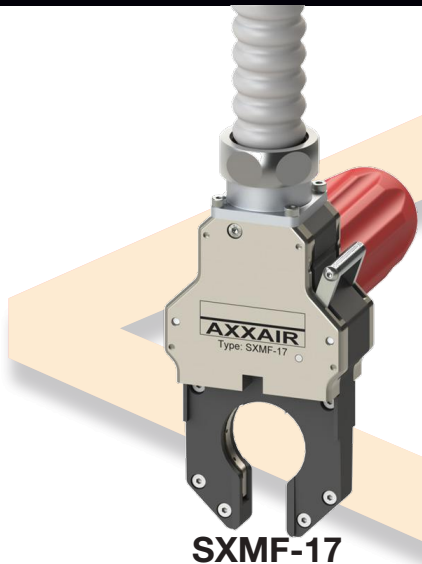

SXMF-17



SXMF-17 with mounted cassette

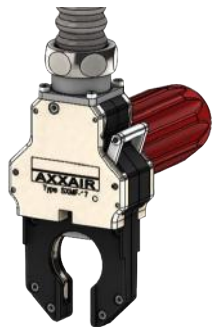

The SXMF-17 machine can weld different tube configurations (Tube/Tube – Tube/elbow union– Fitting/Fitting - ...), 3 cassettes and various accessories are available.



Please refer to the following pages in order to find the products' codes and sideplates' configurations.

The head SXMF-17 is delivered with:

- A transport case
- Tool to set up the tungsten
- Tool to adjust the tungsten
- Tool to set up the collets
- User manual

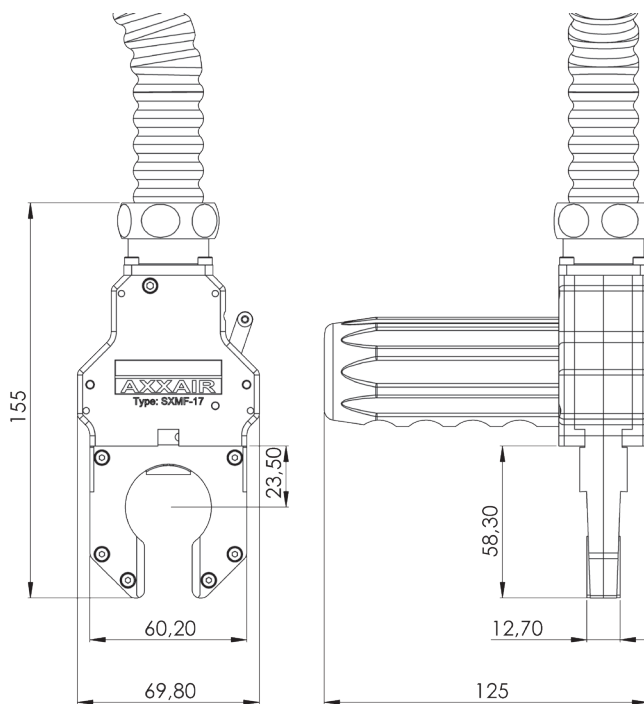

Product Code	Description	Tube welding machine for the following diameters (in mm):	Diameter electrode	Weight without cable	Customs code	Dimensions
SXMF-17	Welding machine SXMF-17	1/8" to 5/8" ø 3 - ø17.2 mm	0.040» Ø1.0 mm	1.4 lbs. (0.6 kg)	85153 10000	See above



AXXAIR Sideplates for SXMF-17

AXXAIR
INNOVATIVE ORBITAL SOLUTIONS

The cassettes offer multiple weld configurations and can be combined accordingly. Thus you will have complete cassettes such as our tube-tube cassettes but for the other configurations of the cassettes will have to choose as a kit of left Side plate and right side plate to the central body.

They have a special treatment that offer a very good conductivity and hard surface finish for durability.

AXXAIR has 3 types of sideplates :

- Model «Standard» is used for tube clamping
- Model called «Large» for Fitting clamping
- Model called «Thin» to clamp tubes below 12.7 mm straight length .

You always need the central body in combination of one of the side plates depending on what you are clamping. The combinations are multiple and the central body is mandatory in all combinations. You have to pay attention to have the clamping levers on the same side (always use one left and one right except for fitting where it does not matter).

Attention: sideplates will have different collets.



Adaptable

In order to make your Swagelockcassettes compatible with the SXMF-17, AXXAIR has designed an adapter kit for the Swagelok cassettes.

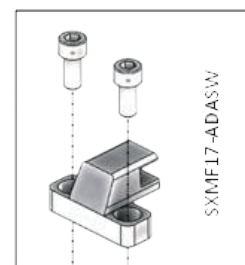

Flexible

Combine the side-plates with the central body depending on your applications.

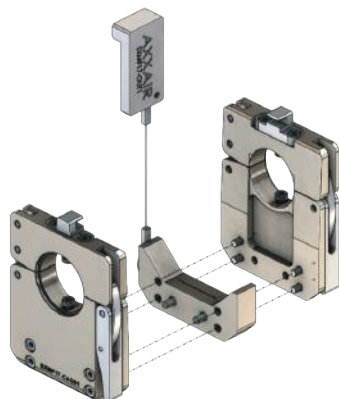

Precise

Each cassette model of AXXAIR has its own references of jaws corresponding to the specific characteristics of the parts to be clamped.

All of AXXAIR's clamping collets made of stainless steel.

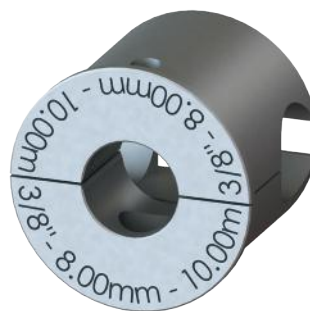

Standard Cassettes & Sideplates

AXXAIR

INNOVATIVE ORBITAL SOLUTIONS

SXMF17-CA01



Standard cassette SXMF		Customs code : 8515900090
Description	Product code	
Standard Cassette SXMF Tube-Tube (complet kit)	SXMF17-CA01	
Standard right sideplate	SXMF17-CAD01	
Standard left sideplate	SXMF17-CAG01	
Standard central body SXMF (common to all siteplates)	SXMF17-CAM01	

SXMF-OUT1 included with the central body (SXMF17-CAM01)

SXMF17-CAG01



SXMF17-CAM01

Recommended standard cassette set for your microfit welds. Subsequently, the thin or wide sideplates can be ordered for specific welds.

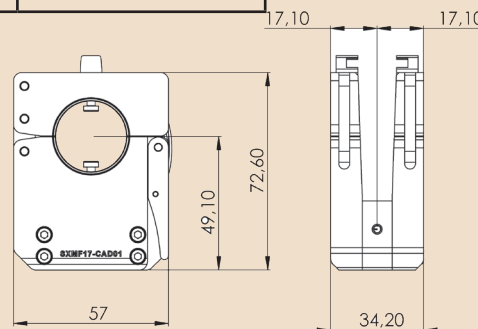

SXMF17-CAD01

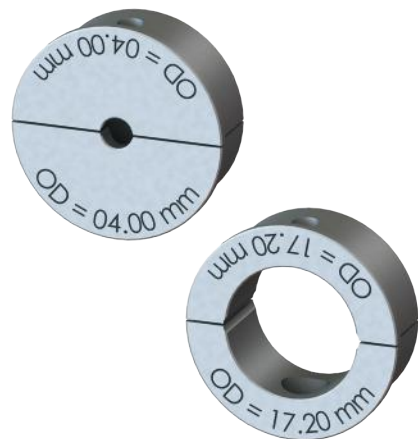

Minimal straight length of the tube: 0.689» (17.50 mm)

Collets for standard siteplates			Customs code 8515900090	
Product code	Ø in inches		Product code	Ø in mm
SMX17-03.175	1/8		SMX17-03	3.00
SMX17-04.763	3/16		SMX17-04	4.00
SMX17-06.35	1/4		SMX17-05	5.00
SMX17-07.938	5/16		SMX17-06	6.00
SMX17-09.525	3/8		SMX17-08	8.00
SMX17-12.70	1/2		SMX17-09	9.00
SMX17-14.287	9/16		SMX17-10	10.00
SMX17-15.875	5/8		SMX17-11	11.00
<p>These jaws (sold by 2) are compatible only with the standard siteplates</p>			SMX17-12	12.00
			SMX17-14	14.00
			SMX17-15	15.00
			SMX17-16	16.00
			SMX17-17.2	17.20



Wide Sideplate (right/left)



Wide siteplate (right and left) for SXMF		Customs code : 8515900090
Description	Product code	
Wide sideplate	SXMF17-CADG03	
Standard central body SXMF (common to all siteplates)	SXMF17-CAM01	

Wide to order to clamp the following fittings.



Minimal straight length of the welding piece: 1.189" (30.20 mm)

Tube collets for wide siteplate			Customs code : 8515900090	
Product code	Ø in inches		Product code	Ø in mm
SMX17-LT03.175	1/8		SMX17-LT03	3.00
SMX17-LT06.35	1/4		SMX17-LT06	6.00
SMX17-LT09.525	3/8		SMX17-LT08	8.00
SMX17-LT12.70	1/2		SMX17-LT10	10.00
SMX17-LT15.875	5/8		SMX17-LT12	12.00
These jaws (sold by 2) are compatible only with the wide siteplates				

Fitting collets for wide siteplate		Customs code : 8515900090
		Product code SMX17-LRA Fitting body size 1/8 in, 1/4 in 6 mm Fitting type Body Union Elbow or Body Union Tee
		Product code SMX17-LRC Fitting body size 1/2 in 12 mm Fitting type Body Union Cross



Thin sideplates



Left thin sideplate



Right thin sideplate

Thin siteplates		Customs code : 855900090	
Description	Product code		
Right thin sideplate	SXMF17-CAD02		
Left thin sideplate	SXMF17-CAG02		
Standard central body SXMF (common to all sideplates)	SXMF17-CAM01		

It is possible to order the entire cassette assembly or only the right or left sideplates with the center body for a customized configuration.

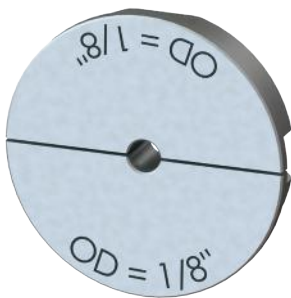

Minimal straight length of the tube: 0.5» (12.70 mm)

Collets for thin sideplates			Customs code : 855900090	
Product code	Ø in inches		Product code	Ø in mm
SMX17-F03.175	1/8		SMX17-F03	3.00
SMX17-F06.35	1/4		SMX17-F06	6.00
SMX17-F09.525	3/8		SMX17-F08	8.00
SMX17-F12.70	1/2		SMX17-F12	12.00

These jaws (sold by 2) are only compatible with the thin sideplates



Orbital welding (Microfit head) - Accessories



Cable extension		Customs code : 8515900090
Product code	Length	Net weight
SAFS-05MAX	5m	7 kg
SAFS-10MAX	10m	14 kg

The SXMf-17 machines is delivered with a cable of 5 metres

To increase the operating distance between the welding head and the SAXX generator, we offer cable extensions.

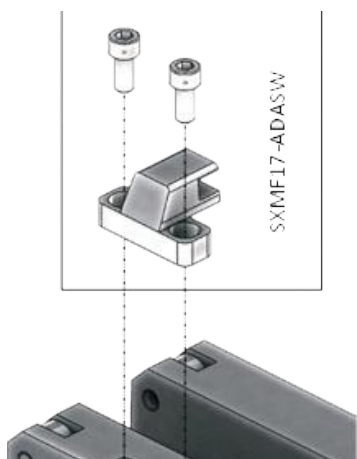

Screw kit for Swagelok		Customs code : 8515900090
Description	Product code	
Adaption kit for Swagelok cassettes	SXMf17-ADASW	

This kit also includes the screw tightening key (BTR 3/32 ").

Tightening torque of fixing screws: 0.5 Nm max.

Orbital welding (Microfit head) - Consumables



Electrodes for SXMf17		Customs code 8515900010	
Product code	Outside diameter of the tube to be welded		Electrode length
	inches	mm	
SCE10-20.0	1/8, 3/16, 1/4	3, 6	20.0mm
SCE10-17.5	5/16, 3/8, 1/2	8, 10, 12	17.5 mm
SCE10-15.0	5/8, 9/16	14, 15, 16, 17.3	15.0mm

-A range of electrodes is available to meet the constraints of the SXMf-17 head:
 - diameter of 0.040» (1,02mm) with the length adapted to the tube diameter.
 - sold per pack of 10

